

MO'track'n'control™

The most advanced product tracking and control solution available today

MO'track'n'control™ A complete product tracking and control solution that revolutionises the way factories track product and control their plants. Seamless integration to what is presently a very costly and complex process.

The robust nature of the technology means that there are less points at which communication can breakdown in a production environment

MO'track'n'control™ allows multiple devices to be connected through the unit, radically reducing the amount of technology needed in the industrial environment

Tracking, by tagging and scanning, reduces processing time by removing manual data entry from the tracking process (ie, it could save minutes every time a person no longer has to key data into a terminal/workstation)

MO'track'n'control™ eliminates errors and only reports "true" information as no manual interfacing is required and data is collected automatically.

It also reduces cost of deployment, is reduced because only one style of connectivity / interface is required

The **MO'track'n'control™** solution is scalable and extensible, allow you to start small and finish big.

Benefits story.

Using **MO'track'n'control™** technology can save organisations time, money and improve productivity in the following ways;

- It minimises the number of unique computing devices needed to connect disparate systems. This reduces the need for multiple computers, PLC's and associated industrial network hardware saving a dramatic cost of equipment. Similar systems can cost 100's of thousands of dollars, the **MO'track'n'control™** solution can dramatically reduce this cost through its simple engineering and design method.
- Because the unit has no "moving parts" and is designed for the industrial environment it is not subject to dirt, dust, "noise", liquid or other substances in many "non-clean" industrial environment. This makes it extremely robust and reduces the cost of ownership as the units are not subject to breakdown and repair.
- The technology reduces integration to ERP / MES or other MIS systems because there is only one interface required for multiple connections. This has the benefit of saving initial costs through a single setup (not multiple setups), and also reduces the potential for future upgrade costs as there is only one interface to upgrade in the future. Also for less requirement for software.
- The combination of the **MO'track'n'control™** solution and the tagging of items in the production line can increase productivity. This is achieved because tagging reduces the amount of manual data entry needed to record data at any point in the production flow. Making items completely traceable throughout the entire process.

For example

In a meat processing line every time a staff member has to key in vital data about a process on the line, this takes time. If there were three or four stops on the production line each taking 2-3 minutes, that is 10-12



minutes an hour, the automation of the tracking process would eliminate the lost line time and save 10-12 minutes an hour, which is 20% of the time available.

But it doesn't stop there. The software environment is engineered to take advantage of the type of activities that have been specifically reserved for the management IT department. This is due to the fact the hardware and software is more in-line with a desktop PC than the plant floor PLC.

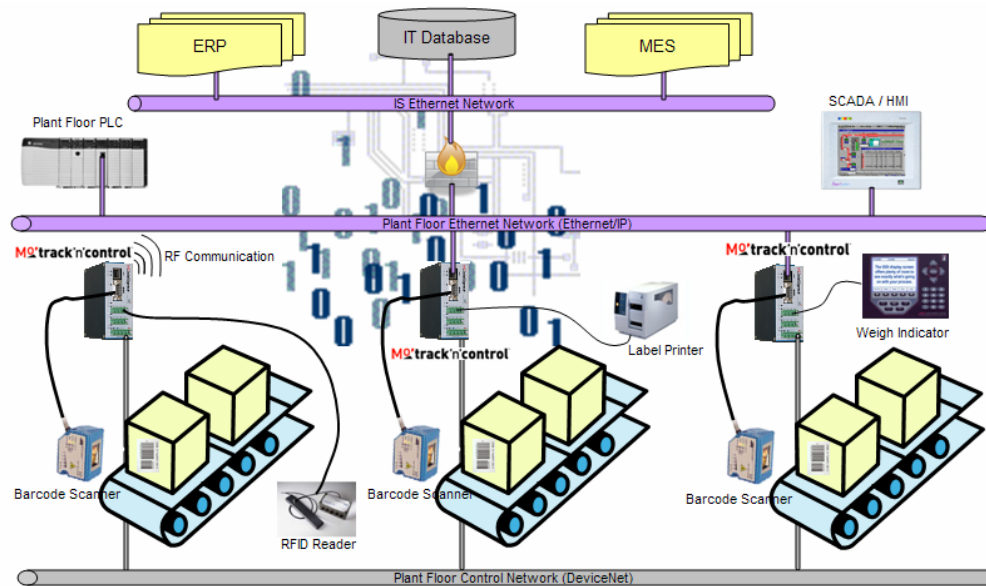

To find out more about the **TCS M9 track'n'control** solution contact TCS (NZ) Ltd. TCS team are happy to discuss any tracking and control issues or queries.

Communications:

The application use of the TCS **M9 track'n'control** is all about communications interfacing to plant equipment for gathering data or controlling devices.

- The Ethernet 10/100 base-T hardware has 60dB common mode rejection with a protection circuitry giving *Electrostatic Discharge* (ESD), surge and *Electrical Fast Transient* (EFT) protection. Isolation between the shield and the ground ensures ground loop isolation. RJ45 connectors are gold plated to prevent corrosion and are rated to withstand high vibration.
- EtherNet/IP™ library is available for integration into an application giving access to an open industrial communications network, as defined by ODVA for industrial applications.
- Serial RS-232, 422, 485 is completely optically isolated with decoupled power supply to ensure electrical isolation and noise immunity from all the industry interference that is commonly present.
- The Control Area Network (CAN) with isolation, full crow bar protection and voltage level detection allows open communication protocols such as DeviceNet™, CANopen, CANKingdom to connect multi-vendor industrial products.
- An Optional 2.4Ghz Wi-Fi IEEE 802.15.4 compliant link satisfies the unique needs of low-cost, low-power wireless networks delivering critical data between devices reliably.

Power Supply:

The 24VDC power supply is designed to withstand the industrial plant floor environment and has a step-down (buck) switching regulator. The power supply is electronically fused with reverse diode protection, and transient and harmonic suppression.

Hardware:

Based on an Intel® XScale processor with 64Mb RAM and 32Mb Flash, including battery backup RAM and real-time clock (RTC).

Software:

The TCS **MO' track'n'control** is designed with flexibility in mind and to permit a multitude of industrial applications to be addressed.

- The operating system (RTOS) is MS Windows.CE.net 5.0 designed specifically for embedded applications.
- EtherNet/IP™, DeviceNet™ and Common Industrial Protocol (CIP™) for industrial communications.
- XML (Extensible Markup Language) Parser. Software to read XML documents identifies XML tags and passes the data to the application.
- SQLite. An ACID (Atomicity, Consistency, Isolation, and Durability) - compliant relational database management system contained in a relatively small C library.
- ISaGRAF IEC 61131 / 61499, SFC and Ladder rung logic. A function block programming language that provides true distributed control / intelligence application.
- C++ programming environment to provide object-oriented programming, software portability, brevity, modular programming, compatibility and speed.

Electrical / Mechanical Specifications

Dimensions:	115 mm x 95 x 38 mm
Weight:	124grams
Voltage:	12-24VDC
Current:	150mA
Enclosure:	Milled Aluminium
Mounting:	DIN Rail EN50 022,35,45
Ethernet:	RJ45
RS-232	D9 Plug
RS-422/485	Phoenix 4 way
CAN/DeviceNet	Phoenix 5 way
Wi-Fi	2.4Ghz IEEE 802.15.4 compliant
I/O Port	Phoenix 4 way
Operating Temp	0 – 60°C
Storage Temp	-40 to 85°C
Relative Humidity	5 to 95% non-condensing
Optical Isolation	2.5KV rms min

Software Specifications

RTOS	Windows CE Version 5.0
Database	SQLite3
Virtual Machine	JAVA KVM
	XML Parser
	Web server
Communications	CIP (Common Information Protocol)
	EtherNet/IP™
	DeviceNet™
	Ethernet TCP/UDP/IP
	CAN (Control Area Network)
	Wifi IEEE 802.15.4 compliant
COM Component Programming	Microsoft XML Parser
	C++
	IEC-61131 / 61499 Function Block
	Sequential Function Chart
	Ladder Rung Logic

Hardware Specifications

Processor	Intel PXA 255 ARM9 X-Scale
Flash	32Mb
RAM	64Mb
RTC	
Ethernet	10 / 100 base-T
CAN	125 – 500kbaud
RS-232	1.2 – 115.2 kbaud
RS-422/485	1.2 – 115.2 kbaud
Wi-Fi	Maxstream XbeePro

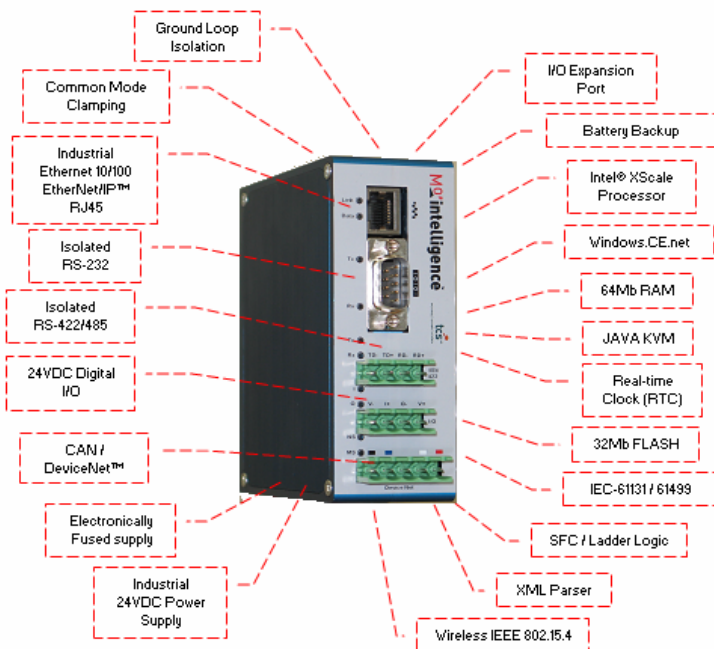

Phone: +64 7 849 7729

Fax: +64 7 849 2548

Email: peter.tait@tcs-nz.co.nz

Web Site: www.tcs-nz.com